

DC-DC CONVERTER 110/24 V DC

110/24 V DC, 8,3 A

CP10.241-60

PSU 96-110 V DC/24-28 V DC, 8.3 A, Railway EN50155

- Width 39 mm
- 94,5 % efficiency
- Acc. to EN 50155 railway application standard
- Conformal coated PC-boards
- Wide temperature range -40°C...+70°C



PRODUCT DESCRIPTION

The DC/DC converter CP10.241-60 is designed specifically for railway & transportation applications. It is approved according to the EN 50155 standard, which is an international standard covering electronic equipment used on rolling stock for railway applications. The standard covers aspects such as temperature, humidity, shock, vibration, EMI and other parameters. Because of these requirements, the unit is equipped with conformal coated pc-boards.

The unit features a DC-OK signal contact for remote monitoring, and quick-connect spring-clamp terminals for a reliable connection even when mechanical vibration and shock are involved. The unit also covers an extreme wide temperature range from -40°C up to +70°C with full output current.

This DC/DC converter comes in a very compact housing and requires only 39mm space on the DIN-rail due to the high efficiency and low power losses. The high efficiency is achieved by utilizing cutting edge technology and other unique design techniques.

SPECIFICATIONS

Input voltage DC	110 V
Input voltage dc min	67 V DC
Input voltage dc max	154 V DC
Inrush current	Typ. 2,5 A @ 110 V DC
Max entrance tripple	15 V pp
Type Power Supply	DC-DC
Start-Up Delay	600 ms

Output voltage	24 V DC
Output voltage min	24 V DC
Output voltage max	28 V DC

Output Current	8.3 A
Effect	200 W
Ripple. max	50 mV pp
Temperature Range Without Derating From	-40 °C
Temperature Range Without Derating To	70 °C

Efficiency	94.5 %
Life span	119000 h @ 110 V DC, 8,3 A, 40 °C
MTBF (IEC 61709)	tbd

Width	39 mm
Height	124 mm
Depth	117 mm
Weight	0.62 kg

Clamp type	Spring-clamp
-------------------	--------------

Series	Dimension C
Approvals	CE, EN 50155
DC relay output	Yes
Material Protection	Aluminium
Keep time	Typ. 45 ms @ 110 V DC, 8,3 A
IP Class	IP20

Conformal coated	Yes
-------------------------	-----

Fig. 6-2 Dynamic output current capability, typ.

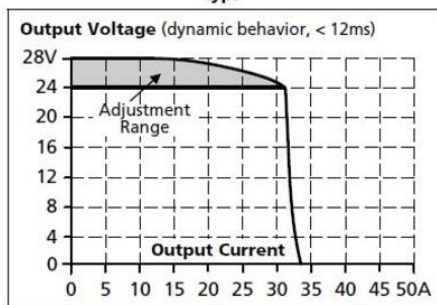

Fig. 6-1 Output voltage vs. output current, typ.

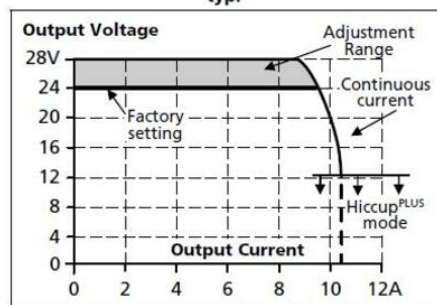

Fig. 16-1 Output current vs. ambient temp. at 24V output voltage

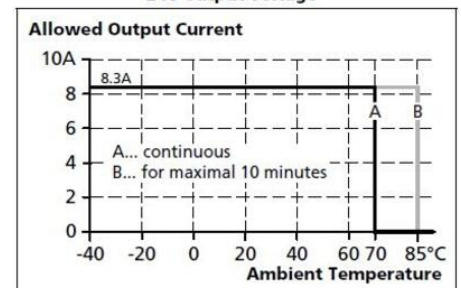

Fig. 10-1 Efficiency vs. output current, at 24V, typ.

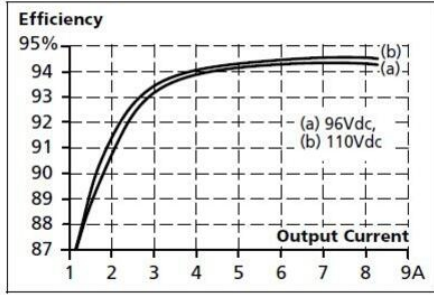

Fig. 6-3 Short-circuit on output, Hiccup^{PLUS} mode, typ.

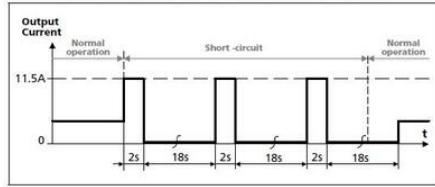

Fig. 14-1 Front side



Fig. 22-1 Front view

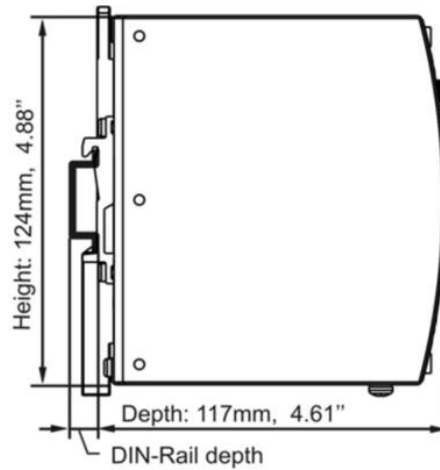
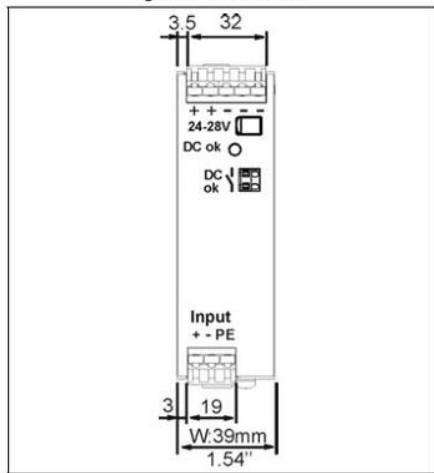

Fig. 6-2 Dynamic output current capability, typ.

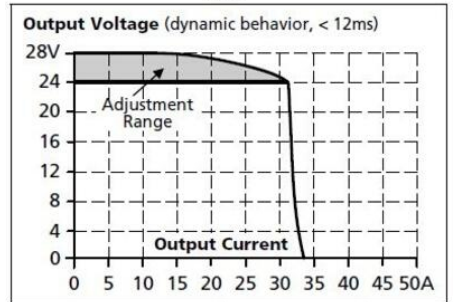

Fig. 6-1 Output voltage vs. output current, typ.

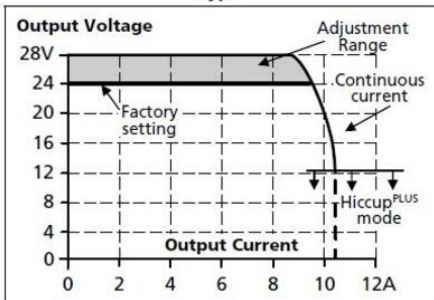

Fig. 16-1 Output current vs. ambient temp. at 24V output voltage

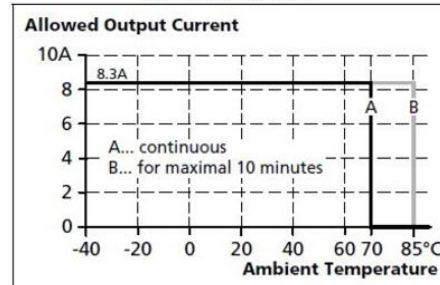

Fig. 10-1 Efficiency vs. output current, at 24V, typ.

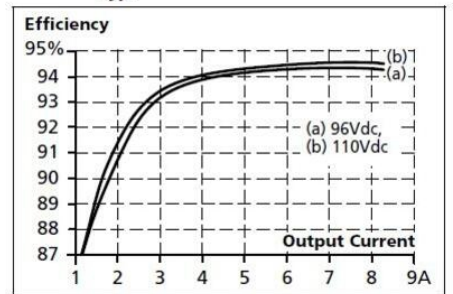

Fig. 6-3 Short-circuit on output, Hiccup^{PLUS} mode, typ.

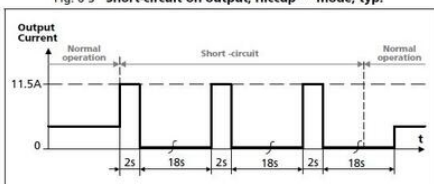

Fig. 14-1 Front side



Fig. 22-1 Front view

