

## SAFETY RADAR

LBK-S01  
Safety radar

- Immune to smoke, dust, water and machining swarf
- Also outdoor use
- -40... +60°C
- SIL2, PLd 4m safety area



### PRODUCT DESCRIPTION

Inxpect produces safety systems for advanced industrial automation and robotics systems based on radar technology. Our systems can detect the entrance and presence of operators in dangerous areas and stop machinery from restarting until the area is free of people, also in the presence of dust, debris, smoke and dirt.

Safety integrity level, SIL2

Performance level, PLd

The LBK-S01 sensor is a smart FMCW (Frequency Modulated Continuous Wave) radar device based on proprietary Inxpect detection algorithms. The sensor sends 24 GHz radio waves and recovers motion information, analyzing the returned signals reflected by both static and moving objects in the operative range.

The sensors perform the following primary functions:

- Motion and scenario analysis.
- Communication via CAN bus to the controller of the motion detection signal.
- Fault reporting and communication of diagnostic information via CAN bus to the controller.

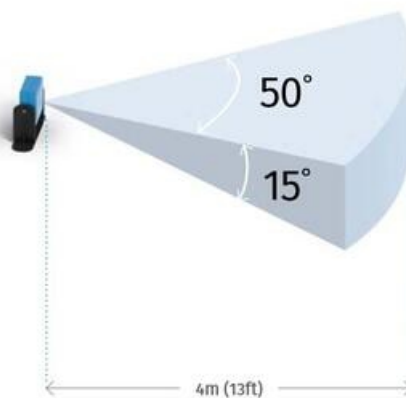
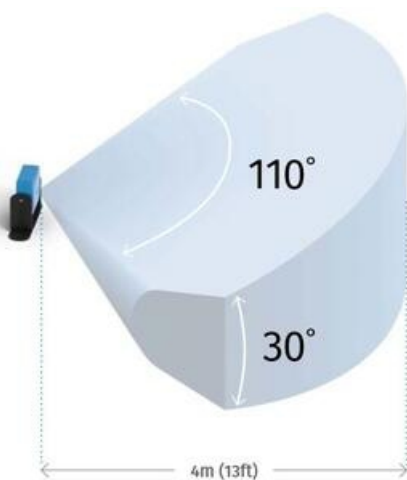

## SPECIFICATIONS

<b>IP Class</b>	IP67
<b>Life span</b>	20 years
<b>Material of body</b>	PA6.6
<b>MTTFd</b>	45
<b>PL</b>	d
<b>Safety category</b>	2
<b>Security Field Max</b>	4 m
<b>SIL</b>	2
<b>Temperature Range The Use Of</b>	-30 °C
<b>Warning Field Max</b>	4 m

