

POWER SUPPLY 3-PHASE, 48 V DC DIMENSION Q SERIES

QT40.481
3-PH POWER SUPPLY 48VDC 960W 20A

- Output current of 20 A
- Up to 95.3% efficiency
- Integrated primary fuses
- High short-circuit currents
- Maximum performance



PRODUCT DESCRIPTION

Pulse Dimension Q is a series power supply with very high performance. QT40.481 have built primary fuses that make it possible to connect the unit without the need for intermediate fuses up to 32 A (UL) which saves space and money. The efficiency is high over a wide load range, which results in reduced power consumption and longer life regardless of load current. An average efficiency is 94.7% with a peak value of 95.4%.

The power loss at idle is very low, 9.5 W. The bonus power provides 50% extra reserve with retained 48 V dc (30 A) which is an advantage when connected loads have high starting currents and to bridge temporary current peaks. The bonus power is limited to 4 seconds to avoid constant overloading of the power supply and wiring. In addition to the bonus effect leave the unit a very high short-circuit current (ms) that helps to secondary fuses. See technical data for example.

Active transient ensure operation also in very störrik electrical environment, also have QT40.481 active inrush current protection, which means a very low starting current, even if the unit has been in operation for a longer time. Especially useful for redundant / parallel-connected systems.

Simple diagnostics via DC-OK relay that falls on the output voltage deviates more than 10% from the set value, a green LED indicates DC-OK, Red LED indicates overload.

The unit can also be remote controlled for on / off function. Three different installation options available, see the "Technical data". Can be used instead of expensive DC contactors when you need to break up the 48 V side (remote control function has no safety circuit and therefore should not be used in the security context).

Active PFC reduces power consumption, harmonics close to zero, in addition, the power distribution in phases much smoother at power asymmetry.

In parallel, the output voltage to be adjusted to the same value on both units (± 100 mV) in single mode or let the factory settings on the unit apply to all units. After possible. adjustment of the output voltage, the switch in the front moved to the "parallel use". The units are now ready to work in parallel.

We recommend clearance of 40 mm, 20 mm below the unit and 5 mm on the sides.

Bonus power

The power supply has a bonus power that enables high power output with maintained 48 V dc for 4 seconds, which is a big advantage when connected loads have high starting current, e.g. motors. How often you can use the bonus power depends on the application. With the diagram and formula below you can calculate the available repeat time for each application. Bonus power is available as soon as the power supply starts and immediately after a short circuit.

Bonus power		Operating characteristics
Po	Nominal load current	
Ppeak	Peak current	
To	Time between bonus power	
Tpeak	Peak current I time	
Operating cycle	Tpeak/ (Tpeak+To)	

To=	$T_{peak} - (\text{operating cycle} \cdot T_{peak}) / \text{operating cycle}$
E.g. Peak current (P_{peak}) is 25A =125 %. Peak time is 3 seconds. Nominal load current (P_o) is 15A. 15 A = 75 % of I_{nom} . According to the diagram the operating cycle is about 0.45. $T_o = 3 - (0.45 \cdot 3) / 0.45 = 3.6$. Maximal repeat time of the bonus power is 3.6 seconds.	

Output characteristics
Remote control function This function permits outputs to be shut down by means of an external signals from e.g. a control system or button. Shutdown occurs immediately and to restart has a delay of about 350 ms. In a shutdown state the output voltage is below 2 V DC and the power is less than 0.5 W.

SPECIFICATIONS

Input voltage range	Wide-range
Number of phases	3
Input voltage AC	380-480 V
Input voltage ac min	323 V AC
Input voltage ac max	576 V AC
Inrush current at 400 V ac typical	5 A
Power Factor at 400 V AC, full load. Typical	0.88
Supply Frequency	50-60 ± 6 %
Power consumption at 400 V ac	1.65 A
Type Power Supply	AC-DC

Output voltage	48 V DC
Output voltage min	48 V DC
Output voltage max	54 V DC
Output Current	20 A
Effect	960 W
Power Reduction Of 60 To 70 ° C	24 W/°C
Ripple. max	150 mV pp
Temperature Range Without Derating From	-25 °C
Temperature Range Without Derating To	60 °C

Efficiency At 400 V AC. Typical	94.7 %
Efficiency At 400 V AC, full load. Typical	95.4 %
Lifetime at 400 V ac, full load and +40 ° C	86000 h
MTBF (IEC 61709) 400 V ac, max loan, +40 °C	375000 h

Width	110 mm
Height	124 mm
Depth	127 mm
Weight	1.5 kg

Clamp type	Spring-clamp
------------	--------------

Series	Dimension Q
Approvals	CB, CE, CSA, GL, UL
DC relay output	Yes
Material Protection	Aluminium
Hold-up time at 400 V AC, full load. Typical.	25 ms
IP Class	IP20
Active Transient	Yes

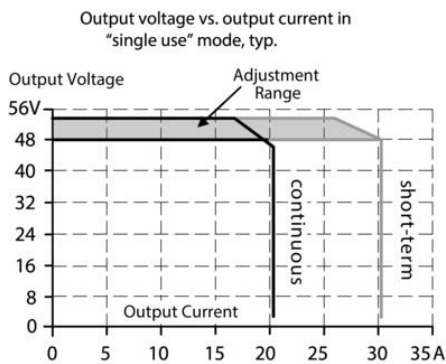

Fig. 6-4 Dynamic overcurrent capability, typ.

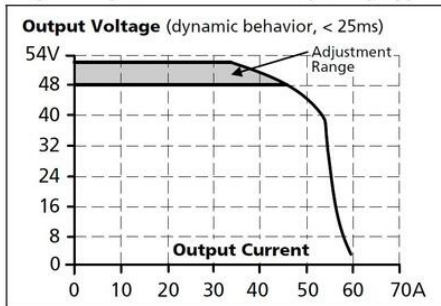

Fig. 17-1 Output current vs. ambient temp.

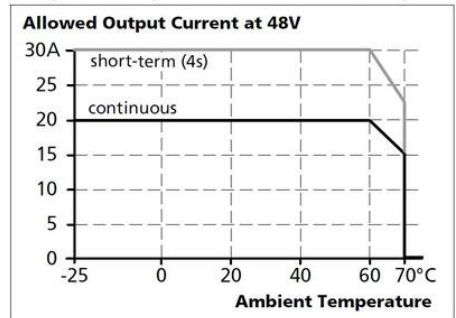

Fig. 6-3 Bonus time vs. output power

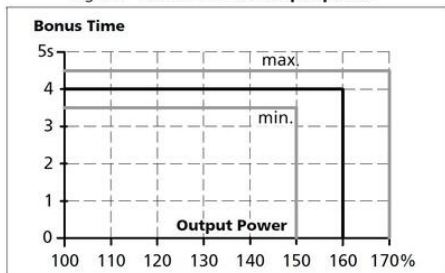

Fig. 11-1 Efficiency vs. output current at 48V, typ.

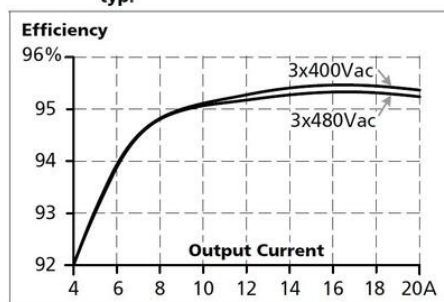
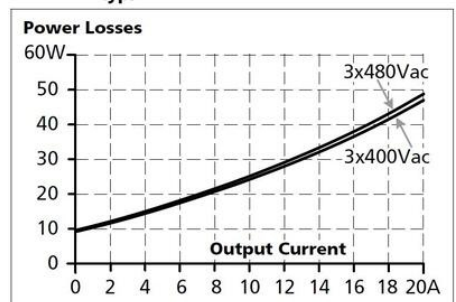

Fig. 11-2 Losses vs. output current at 48V, typ.



Maximal wire length¹⁾ for a fast (magnetic) tripping:

	0.75mm ²	1.0mm ²	1.5mm ²	2.5mm ²
C-2A	74m	89m	146m	190m
C-3A	57m	79m	128m	163m
C-4A	43m	52m	73m	116m
C-6A	19m	25m	27m	57m
C-8A	8m	12m	17m	25m
C-10A	6m	9m	13m	19m
C-13A	3m	5m	7m	10m
B-6A	38m	52m	76m	113m
B-10A	18m	26m	38m	55m
B-13A	12m	19m	29m	42m
B-16A	6m	8m	12m	20m
B-20A	1m	2m	4m	5m

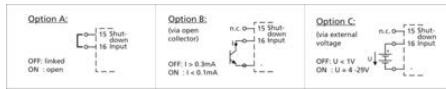

Fig. 15-1 Front side

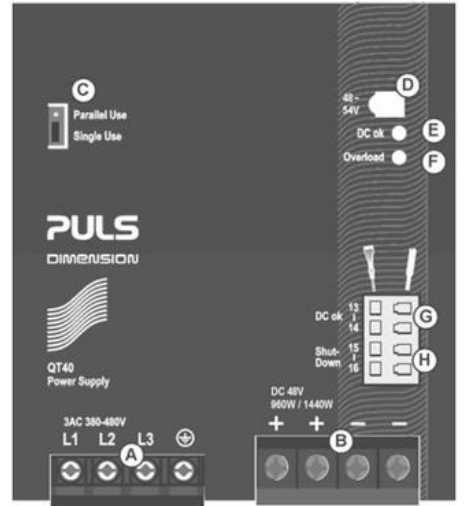
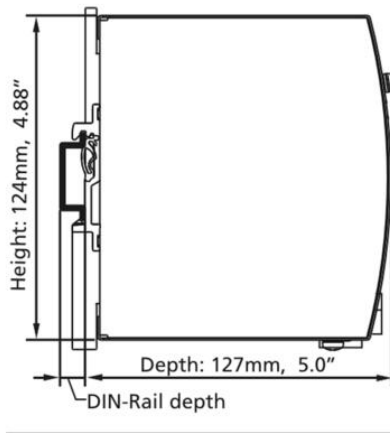
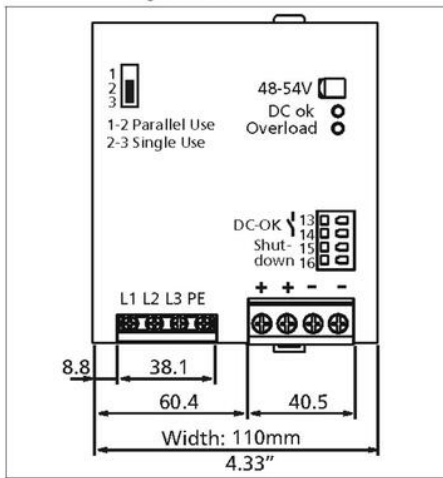

Fig. 22-1 Front view



Output voltage vs. output current in "single use" mode, typ.

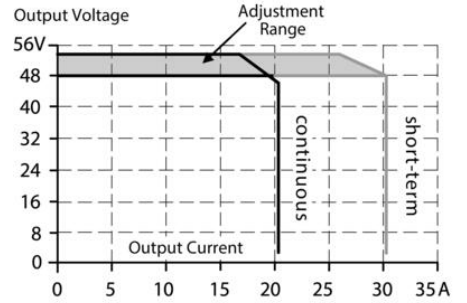

Fig. 6-4 Dynamic overcurrent capability, typ.

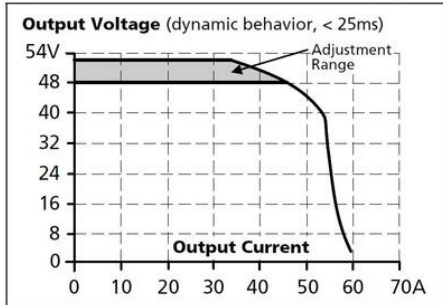

Fig. 17-1 Output current vs. ambient temp.

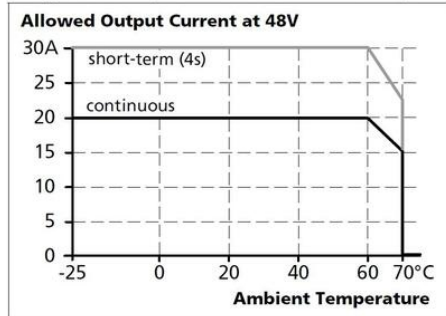

Fig. 6-3 Bonus time vs. output power

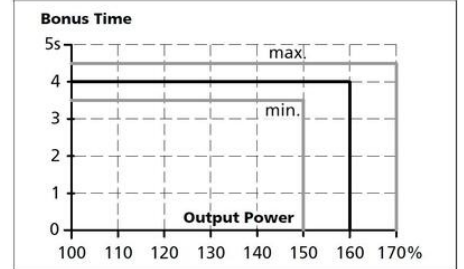

Fig. 11-1 Efficiency vs. output current at 48V, typ.

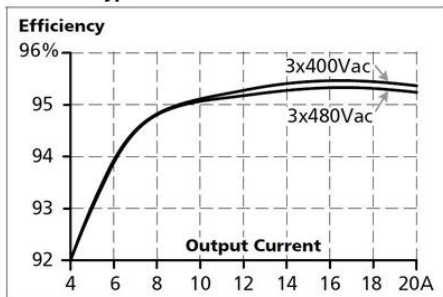
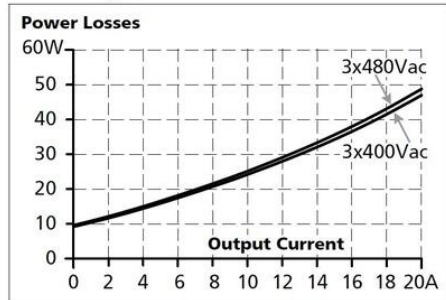

Fig. 11-2 Losses vs. output current at 48V, typ.



Maximal wire length¹⁾ for a fast (magnetic) tripping:

	0.75mm ²	1.0mm ²	1.5mm ²	2.5mm ²
C-2A	74m	89m	146m	190m
C-3A	57m	79m	128m	163m
C-4A	43m	52m	73m	116m
C-6A	19m	25m	27m	57m
C-8A	8m	12m	17m	25m
C-10A	6m	9m	13m	19m
C-13A	3m	5m	7m	10m
B-6A	38m	52m	76m	113m
B-10A	18m	26m	38m	55m
B-13A	12m	19m	29m	42m
B-16A	6m	8m	12m	20m
B-20A	1m	2m	4m	5m

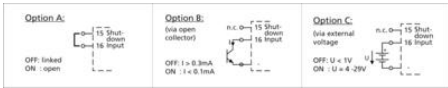

Fig. 15-1 Front side

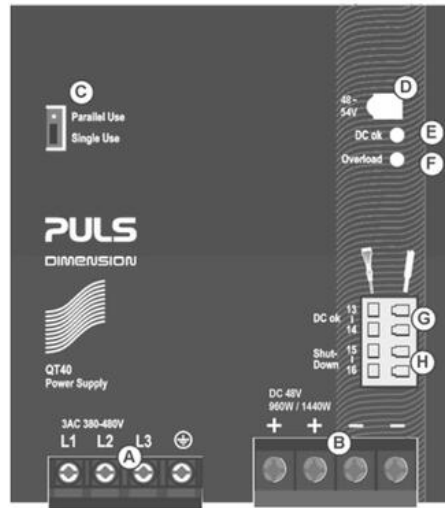

Fig. 22-1 Front view

