

KDS-SR FRAMES & INLAYS

KDS-SR

28506.4

KDS-SR 1-4, Screw frame, Black

- Three parts, many solutions
- Reduced installation time
- Easy assembly from the inside to the outside
- Perfect for pre-assembled cables
- High IP66 protection



PRODUCT DESCRIPTION

Cable entry system KDSClick

The system has a modular design, consisting of only three types of basic components: frames, inlays and sealing sleeves. Unlike conventional systems where the frame must be opened to insert the sealing sleeve and then screwed shut, CONTA-CLIP uses a dimensionally stable solution with a one-piece lightweight frame made from fibre-glass reinforced plastic.

Inlays can be clicked in to achieve the required size for the frame openings. This mechanism enables different frame configurations to be constructed for various cabling requirements and reducing the amount of items that need to be stocked.

There are over 90 different sealing sleeves available for guiding multiple cables through the frame openings. After the corresponding cable is sheathed, the sleeves can be easily inserted (from the inside of the electrical cabinet towards the outside) into the openings that are framed by the inlays.

The sealing sleeves have a conical taper so that they can be easily pressed into the frame openings/inlays. There, they reliably seal up the spaces around the cable. They also provide a secure strain relief mechanism for cables outside of the housing. The sealing sleeves can also be easily released (by pressing inwards) if you need to add or change the cabling. Thus, you can change your cabling without completely removing the frame.

There is an optional inner locking frame that can fit on inside of the electrical cabinet. The locking frame secures the sealing sleeves from within so that they cannot be tampered with or pushed back in adding extra security if required.

The frames are easy to install because it uses the same arrangement of mounting holes that are already standard for most industrial connectors, such as Harting and Walther.

KDS inlays

The KDS inlays are used to convert the KDS-SR screw frames for various combinations of sealing sleeves.

There are four versions of inlays, KDS-Inlay 6, KDS-Inlay 4, KDS-Inlay 2 and KDS-Inlay 1. With these four inlays many configurations can be made without the need for specific frames for each combination.

Features:

- Material: Polyamide PA 6.6
- Colour: black
- Flammability: UL94 V-0
- Temperature range: -40 to +120°C
- Halogen-free, silicone-free
- Protection: IP66

KDS screw frame

The KDS-SR screw frames can be mounted directly onto the standard electrical-cabinet cut-outs for 4 to 24-pole industrial connectors.

After the assembly, assembled cables can easily be fed through the frame from the inside of the cabinet.

The optional inner KDS-IVR locking frame may then be used. It is secured using the four fastening screws on the screw-in frame.

Features:

- Material: Polyamide PA 6.6 glass-fibre reinforced
- Colour: black
- Flammability: UL94 V-0
- Temperature range: -40 to +120°C
- Halogen-free, silicone-free
- Protection: IP66

KDS sealing sleeve inserts

After the wires or cables have been fed in, the KDS-DE thermoplastic sealing sleeves provide an excellent seal (IP66) and also a mechanical strain relief mechanism for the cables. With a selection of 90 different sealing sleeves, perfect solutions can be designed for wire diameters from 2 to 33 mm.

Inserts that will take 2 or 4 cables are available along with special inserts are available for Asi cables.

For flat cables, the KDS-FP system has a wide range of inserts in a smaller frame size.

The material used contains no halogen or silicon. It is also resistant to fuels, oils and greases.

The grey seal sleeves are resistant to acids and alkalis. They are self-extinguishing in accordance with UL 94 V-0.

The black sealing sleeves are suitable for applications with frequent temperature fluctuations because they feature long-term stability and UV stabilization.

Grey seal sleeves

- Material: TPE
- Flammability: UL94 V-0

- Temperature range: -40 to + 90°C (static)
- Halogen-free, silicone-free
- Protection: IP66

Black sealing sleeves

- Material: TPE
- Flammability: UL94 HB
- Temperature range: -40 to +120°C (static)
- Halogen-free, silicone-free
- Higher chemical resistance
- UV-stabilized
- Protection: IP66

SPECIFICATIONS

Approvals	cUL, UL
Color	Black
Country of origin	DE
cUL test standard	C22.2 No. 14-95
Diameter of the screw holes	5.5 mm
Fixing screws	M5
Flamklass	V-0
Glass-fibre reinforced	Yes
Halogen free	Yes
Height	19.6 mm
Installed height	19.6 mm
IP Class	IP66
Length	81 mm
Length of cutout	46 mm
Material	Polyamide
Mounting	Screw on
NEMA class	4x
Number of screw holes	4
Operating temperature from	-40 °C
Operating temperature to	120 °C
Pack Size	1
Sealing material	Polyurethane-based
Silicone-free	Yes
Tariff code	39259020
UL test standard	UL 508
Weight	59.4 g

Width

70 mm

THE OVERWHELMING BENEFITS OF KDSCLICK!

KDS CLICK

- Integrating with your existing system
- Simple installation
- No loss of guarantee
- Fast assembly and disassembly
- Mounting the frame
- Integrating with your existing system
- Simple installation
- No loss of guarantee
- Fast assembly and disassembly
- Mounting the frame
- Integrated audio output
- Safe and secure
- Maximum protection
- Use for most films

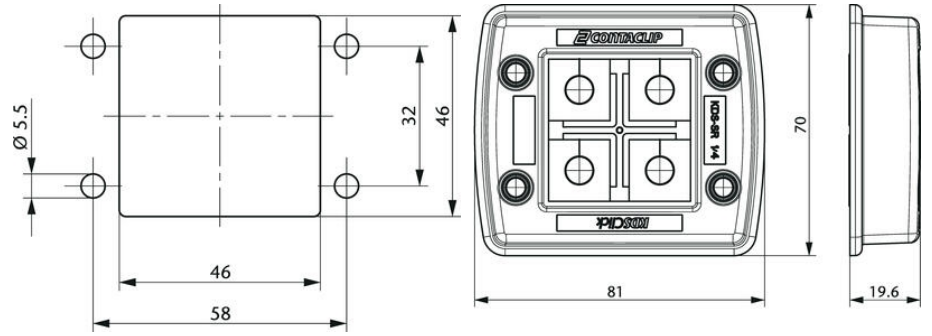

Torque for the frame's mounting screw: 2.5 – 3 Nm